



# Premium M1-M2

Retractable Arms System



# Premium M1

## Retractable Arms System

- Monobloc system with retractable arms.
- The supports (for the arms, tube, gear or motor) are fixed on the 40x40 mm square bar, which allows to move/centre the arms easily at the desired distance and add two or more arms.
- Die casting made arms brackets.
- The arms inclination and position can be adjusted at the factory, saving then time during the final installation.

### → System parts



Assembly example for Premium M1 with 6,00 m width and 2,25 m arms projection. White

DESCRIPTION	CODE	UDS.
EXAMPLE FOR MOTORIZED PREMIUM M1		
Set of retractable Premium arms (2,25 m)	8008-815	1
Set of die casting Premium M1 support, arm to square bar <i>Jeu supports coulés bras/barre M1 Premium</i>	8008-1111	1
Set of square bar/tube M1-M2 supports with nylon bushing, screws and caps	8008-185	1
Set of caps for bar/tube M1-M2 supports <i>Enjoliveurs support axe/barre M1-M2</i>	8008-398	1
Set of frontal adjustments for Premium arm	8008-875	1
Die casting wall/ceiling M1-M2 supports with 2 holes, screws and caps <i>Support mur coulé 2 trous M1-M2 avec vis et embouts</i>	8008-236	7
40x40x3 square aluminum bar	8008-410	7 m
Bambu3 profile <i>Profil Bambu3</i>	8005-334	6 m
Set of caps for Bambu3 profile	8005-340	1
Galvanized round tube with ogive <i>Tube rond à gorge galvanisé</i>	8003-17	6 m
Round cap of 70 mm with round pivot of 12x20 mm	8002-38	1
Logos 50 motor <i>Moteur Logos 50</i>	6005-101	1
50 series bracket (built in and awnings)	6008-3	1
Adapter for 70 mm tube with ogive <i>Accouplement pour axe de 70 mm ogiva</i>	6007-14	1
Cronos 1 remote control	6009-118	1

DESCRIPTION	CODE	UDS.
EXAMPLE FOR PREMIUM M1 WITH GEAR		
Set of retractable Premium arms (2,25 m)	8008-815	1
Set of die casting Premium M1 support, arm to square bar <i>Jeu supports coulés bras/barre M1 Premium</i>	8008-1111	1
Set of square bar/tube M1-M2 supports with nylon bushing, screws and caps	8008-185	1
Set of caps for bar/tube M1-M2 supports <i>Enjoliveurs support axe/barre M1-M2</i>	8008-398	1
Set of frontal adjustments for Premium arm	8008-875	1
Die casting wall/ceiling M1-M2 supports with 2 holes, screws and caps <i>Support mur coulé 2 trous M1-M2 avec vis et embouts</i>	8008-236	7
40x40x3 square aluminum bar	8008-410	7 m
Bambu3 profile <i>Profil Bambu3</i>	8005-334	6 m
Set of caps for Bambu3 profile	8005-340	1
Galvanized round tube with ogive <i>Tube rond à gorge galvanisé</i>	8003-17	6 m
Round cap of 70 mm with round pivot of 12x20 mm	8002-38	1
Driving round cap of 70 mm with square pivot of 13x33 mm <i>Embout mâle côté manoeuvre, sortie carrée de 13x33 mm</i>	8002-28	1
Ciclon gear 1/11, 120 mm eye, rolled	8001-192	1
Lacquered handcrank, zinc plated steel hook (1,50 m) <i>Manivelle laquée crochet zingué (1,50 m)</i>	8009-10	1
Polyamide handle lock	7010-39	1

# Premium M2

## Retractable Arms System

- Monobloc system with retractable arms.
- The supports (for the arms, tube, gear or motor) are fixed on the 40x40 square bar, which allows to move/centre the arms easily at the desired distance and add two or more arms.
- Extruded arms brackets.
- The arms inclination and position can be adjusted at the factory, saving then time during the final installation.

### → Sys parts



Assembly example for Premium M2 with 6,00 m width and 2,25 m arms projection. White

DESCRIPTION	CODE	UDS.
EXAMPLE FOR MOTORIZED PREMIUM M2		
Set of retractable arms (2,25 m)	8008-815	1
Set of extruded Premium M2 support, arm to square bar	8008-995	1
Set of square bar/tube M1-M2 supports with nylon bushing, screws and caps	8008-185	1
Set of caps for bar/tube M1-M2 supports	8008-398	1
Set of frontal adjustments for Premium arm	8008-875	1
Die casting wall/ceiling M1-M2 supports with 2 holes, screws and caps	8008-236	7
40x40x3 square aluminum bar	8008-410	7 m
Bambu3 profile	8005-334	6 m
Set of caps for Bambu3 profile	8005-340	1
Galvanized round tube with ogive	8003-17	6 m
Round cap of 70 mm with round pivot of 12x20 mm	8002-38	1
Logos 50 motor	6005-101	1
50 series bracket (built in and awnings)	6008-3	1
Adapter for 70 mm tube with ogive	6007-14	1
Cronos 1 remote control	6009-118	1

DESCRIPTION	CODE	UDS.
EXAMPLE FOR PREMIUM M2 WITH GEAR		
Set of retractable Premium arms (2,25 m)	8008-815	1
Set of extruded Premium M2 support, arm to square bar	8008-995	1
Set of square bar/tube M1-M2 supports with nylon bushing, screws and caps	8008-185	1
Set of caps for bar/tube M1-M2 supports	8008-398	1
Set of frontal adjustments for Premium arm	8008-875	1
Die casting wall/ceiling M1-M2 supports with 2 holes, screws and caps	8008-236	7
40x40x3 square aluminum bar	8008-410	7 m
Bambu3 profile	8005-334	6 m
Set of caps for Bambu3 profile	8005-340	1
Galvanized round tube with ogive	8003-17	6 m
Round cap of 70 mm with round pivot of 12x20 mm	8002-38	1
Driving round cap of 70 mm with square pivot of 13x33 mm Embout mâle côté manoeuvre, sortie carrée de 13x33 mm	8002-28	1
Ciclon gear 1/11, 120 mm eye, rolled	8001-192	1
Lacquered handcrank, zinc plated steel hook (1,50 m) Manivelle laquée crochet zingué (1,50 m)	8009-10	1
Polyamide handle lock	7010-39	1

# Premium M1

Recommended for up to 6,00 m width and 3,00 m arms projection, or 5,00 m x 3,50 m, with 2 arms.

Assembly for up to 9,00 m width x 3,00 m projection with three arms, although it allows larger dimensions thanks to the possibility of making joints and adding more arms.

Assembly with the gear outside, inside, to the left or to the right, and with motor.

Assembly option with Spiral box and Flat Hood.

## Cutting instructions

Cutting measures for minimum width (m) / Mesures de coupe pour largeurs minimales (m)										
Arms projection	1,25	1,50	1,75	2,00	2,25	2,50	2,75	3,00	3,25	3,50
2 arms awning minimum width	1,722	1,973	2,225	2,556	2,808	3,060	3,391	3,643	3,894	4,146
Quantity universal support	2	2	2	3	3	3	4	4	4	4
3 arms awning minimum width	2,493	2,870	3,248	3,745	4,122	4,500	4,997	5,374	5,751	6,129
Quantity universal support	3	3	3	4	4	5	5	5	6	6
4 arms awning minimum width	3,264	3,767	4,271	4,933	5,436	5,940	6,603	7,106	7,609	8,112
Quantity universal support	3	3	4	4	5	5	6	7	7	7

Note: With the gear outside. Subtrac 2,5 cm. with the gear inside. For minimum widths at the limit when using gear, a 120 mm eye should be considered.

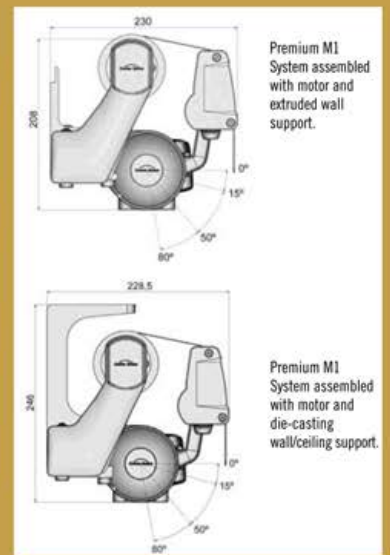

# Premium M2

Recommended for up to 6,00 m width and 3,00 m arms projection, or 5,00 m x 3,25 m, with 2 arms.

Assembly for up to 9,00 m width x 3,00 m projection with three arms, although it allows larger dimensions thanks to the possibility of making joints and adding more arms.

Assembly with the gear outside, inside, to the left or to the right, and with motor.

Assembly option with Spiral box and Flat Hood.

## Cutting instructions



Cutting measures for minimum width (m)										
Arms projection	1,25	1,50	1,75	2,00	2,25	2,50	2,75	3,00	3,25	3,50
2 arms awning minimum width	1,692	1,943	2,195	2,526	2,778	3,030	3,361	3,613	3,864	4,116
Quantity universal support	2	2	2	3	3	3	4	4	4	4
3 arms awning minimum width	2,467	2,844	3,222	3,719	4,096	4,474	4,971	5,348	5,725	6,103
Quantity universal support	3	3	3	4	4	5	5	5	6	6
4 arms awning minimum width	3,241	3,745	4,248	4,911	5,413	5,917	6,580	7,083	7,586	8,089
Quantity universal support	3	3	4	4	5	5	6	7	7	7

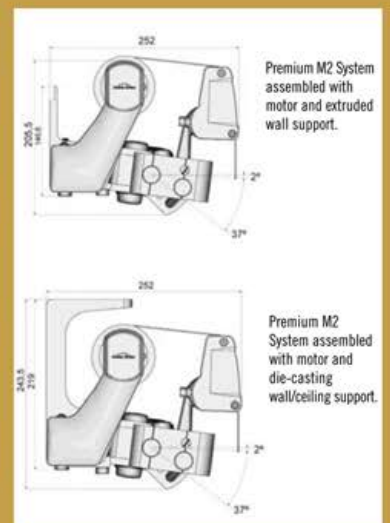

Note: With the gear outside. Subtrac 2,5 cm. with the gear inside. For minimum widths at the limit when using gear, a 120 mm eye should be considered.





# Premium M1- M2

	DESCRIPTION		
	Set of Premium retractable arms		1
	Colour	Strength of 2 Premium Arms	
White	Arms Projection (m)	Strength (Kg)	
8008-785	1,50	50,5	
8008-795	1,75	55,1	
8008-805	2,00	61,2	
8008-815	2,25	66,5	
8008-825	2,50	71,3	
8008-835	2,75	77,9	
8008-845	3,00	83,6	
8008-855	3,25	87,5	
8008-865	3,50	91,7	

	DESCRIPTION		
	Set of die casting Premium M1 support, arm to square bar		1
8008-1111	White		



	DESCRIPTION		
	Set of extrusion Premium M2 support, arm to square bar		1
8008-995	White		

	DESCRIPTION		
	Set of square bar/tube M1-M2 supports with nylon bushing, screws and caps		1
8008-185	White		



	DESCRIPTION		
	Transmission bar/tube M1-M2 support with nylon bushing, screws and caps		1
8008-384	White		



	DESCRIPTION		
	Set of caps for bar/tube M1-M2 supports		10
8008-398	White		



	DESCRIPTION		
	M1-M2 central support with screws and caps		1
8008-306	White		

	DESCRIPTION		
	Set of frontal adjustments for Premium arm		25
8008-875	White		



	DESCRIPTION		
	Set of lower adjustments for Premium arm		25
8008-885	White		

	DESCRIPTION		
	Extruded M1-M2 wall supports with screws and caps		10
8008-180	White		

	DESCRIPTION		
	Die casting wall/ceiling M1-M2 support with 2 holes, screws and caps		5
8008-236	White		

	DESCRIPTION		
	Die casting wall/ceiling M1-M2 support with 4 holes, screws and caps		5
8008-241	White		

	DESCRIPTION		
	40x40x1,5 square steal bar		4
		L/m	
8008-484	White	5,80	

	DESCRIPTION		
	40x40x3 square aluminum bar		4
		L/m	
8008-101	White	5,80	
8008-410	White	7	

	DESCRIPTION		
	Set of plastic caps for 40x40 square bar		25
8008-202	White		



# Premium M1-M2

Retractable Arms System

EN-1933:1999 Water resistance selection abacus

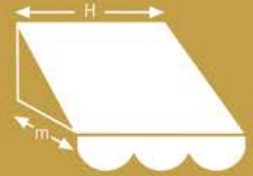

## Premium M2

5,50	6,00	H m	2,00	2,50	3,00	3,50	4,00	4,50	5,00	5,50	6,00	H m
1	1	3,50	IM	IM	IM	IM	IM	IM	IM	IM	IM	3,50
2	2		IM	IM	IM	IM	IM	IM	IM	IM	IM	
1	1	3,25	IM	IM	IM	IM	1	1	1	IM	IM	3,25
2	2		IM	IM	IM	IM	2	2	2	IM	IM	
2	2	3,00	IM	IM	IM	IM	2	2	2	2	2	3,00
2	2		IM	IM	IM	IM	2	2	2	2	2	
2	2	2,75	IM	IM	IM	2	2	2	2	2	2	2,75
2	2		IM	IM	IM	2	2	2	2	2	2	
2	2	2,50	IM	IM	3	3	3	3	3	2	2	2,50
2	2		IM	IM	2	2	2	2	2	2	2	
3	3	2,25	IM	IM	3	3	3	3	3	3	3	2,25
2	2		IM	IM	2	2	2	2	2	2	2	
3	3	2,00	IM	3	3	3	3	3	3	3	3	2,00
2	2		IM	2	2	2	2	2	2	2	2	
3	3	1,75	IM	3	3	3	3	3	3	3	3	1,75
2	2		IM	2	2	2	2	2	2	2	2	
3	3	1,50	3	3	3	3	3	3	3	3	3	1,50
2	2		2	2	2	2	2	2	2	2	2	
3	3	1,25	3	3	3	3	3	3	3	3	3	1,25
2	2		2	2	2	2	2	2	2	2	2	

Different classes have been fulfilled according to the described conditions at Gaviota Simbac initial tests.

### WIND RESISTANCE

#### Water Flood Resistance

17 l / m<sup>2</sup> x h

56 l / m<sup>2</sup> x h

### WIND RESISTANCE

Class	Maximum Wind Speed	Pressure
1	28 Km/h	40 N/m <sup>2</sup>
2	38 Km/h	70 N/m <sup>2</sup>
3	49 Km/h	110 N/m <sup>2</sup>

### PREMIUM M1-M2 MOTORIZATION

Arms projection in meters	Width in meters				
	3,00	4,00	5,00	6,00	7,00
1,25		LOGOS 30 / GM 30			LOGOS 40 / GM 40
1,50		LOGOS 30 / GM 30			LOGOS 40 / GM 40
1,75		LOGOS 30 / GM 30			LOGOS 40 / GM 40
2,00		LOGOS 30 / GM 30			LOGOS 40 / GM 40
2,25		LOGOS 30 / GM 30			LOGOS 50 / GM 50
2,50		LOGOS 40 / GM 40			LOGOS 50 / GM 50
2,75		LOGOS 40 / GM 40			
3,00		LOGOS 40 / GM 40			
3,25		LOGOS 40 / GM 40			
3,50		LOGOS 40 / GM 40			



## CROCI AUSTRALIA

88-90 Derby Street, Pascoe Vale, 3044  
Tel: (03) 9354 4777 Fax: (03) 93541944

[sales@croci.com.au](mailto:sales@croci.com.au)  
[www.croci.com.au](http://www.croci.com.au)

*For more information: / Pour plus d'information:*

